

Tarso Supinator® | Pronator® | Medius® | Dobbs

MORKELL

KEEPINGPACE | Pulman International® | DARCO®





TABLE OF CONTENTS



PAGE 4

◀ TM2000 Series®
Symmetrical straight last shoes with added depth to accommodate AFO's and orthotics.



PAGE 5

◀ Tarso Medius®
Symmetrical straight last shoes with no wedges for mild varus and in-toeing.



PAGE 6-9

◀ Tarso Medius®
Straight last with Thomas heel. Added medial support without inflare.



PAGE 11

◀ Tarso Pronator®
Reverse Last/Outflare, with outer border sole and heel wedges, and long medial counters, for varus, in-toeing and for corrected club foot.



PAGE 12

◀ Tarso® Open Toe Boots
Straight last boots used in **PONSETI METHOD** of treating **Clubfoot** and Outflare (reverse) last Boots for treatment of **Metatarsus Adductus**.



PAGE 13

◀ Denis Browne Splints & Devices
Tarso Splints and Fillauer Splints recommended for use in **PONSETI METHOD** of treating clubfoot.



PAGE 14-15

◀ Tarso® Brace Boots
Children's and men's, lace to toe surgical pattern.

Tarso Supinator® ▶
Inflare last for plano-valgus (flat) feet and severe toe-out.



PAGE 17

Foot Supports ▶
Scaphoid pads, Sneaker Molds, Thomas Heels, Flexibly Supports, Anti-shox Heel Cradles, Heel Cups, Corrective Heel Seats.



PAGE 18

Findings & Accessories ▶
Measuring devices, shoe adhesive & thinner, tongue pads, heel pads, heel wedges.



PAGE 19

Aetrex™, Ambulator™ ▶
Footwear and Accessories
Extra deep comfort shoes for Men and Women with Diabetes, Arthritis, and other foot problems. Caresox™, Seamfree™ Socks.



PAGE 20

Pulman International Comfort ▶
Shoes and Rehab Sandals
Washable comfort shoes and sandals for convalescence and rehabilitation.



PAGE 21

DARCO® ▶
Post operative and healing shoes and cast boots.



PAGE 22-23

MARKELL

A NOTE ABOUT TARSO SHOE SIZES AND SIZE RANGES

U.S. shoe sizes are calibrated in Whole and Half size increments. There are 3 Whole sizes to the inch and there are 6 Half sizes. This means that when you go up a half size in length you are increasing by about $\frac{1}{6}$ ". Young children grow around the clock and so do their shoe size ranges; like a clock from 0000-up to size $13\frac{1}{2}$. Then the sizes start over at 1 in the youth's size range, going up to Youth's size 3 or 4. At this point U.S. shoe sizes diverge into Men's and Women's size ranges. A Women's size 5 is approximately equal to the Youth's size $3\frac{1}{2}$. The Boy's/Men's size range follows directly from Youth's size 3 into Boy's size 4. From size 6 on, the sizes are designated as Men's sizes. With reference to Men's and Women's shoes sizes, it should be noted that there is $1\frac{1}{2}$ - 2 sizes difference between Men's shoe sizes and Women's sizes. For example a women's size 9 is equivalent in length to a men's size 7 or $7\frac{1}{2}$. Looking at it the other way, a Men's size 8 or $8\frac{1}{2}$ shoe will fit a Woman who takes a women's size 10. Shoes are made in a multiple of widths from the narrowest to the widest, designated by the letters B, C, D, E, EE or by the letters N, M, W, WW; which stand for Narrow, Medium, Wide and Extra-Wide. For Tarso shoes offered in N, M, and W widths, N equals B, M equals D, and W equals EE. Please refer to the diagrams and Age/Size groupings below for further clarification on size ranges. Please note that age ranges are only approximate.



INFANTS
Age: 0-24 Months
Sizes: 0000 - 6



TODDLER
Age: 2-5 Years
Sizes: $6\frac{1}{2}$ - 9



CHILD'S
Age: 5-8 Years
Sizes: $8\frac{1}{2}$ - 12

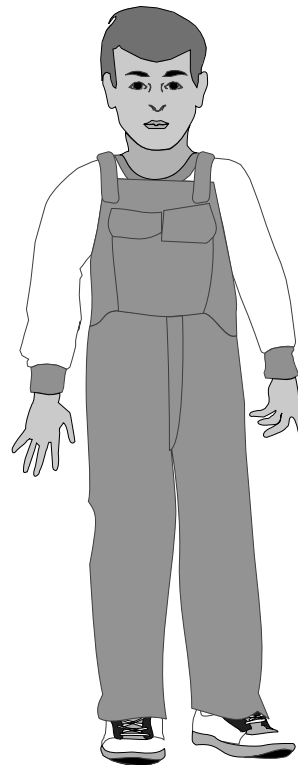

YOUTH'S
Age: 8-10
Sizes: $12\frac{1}{2}$ - 3

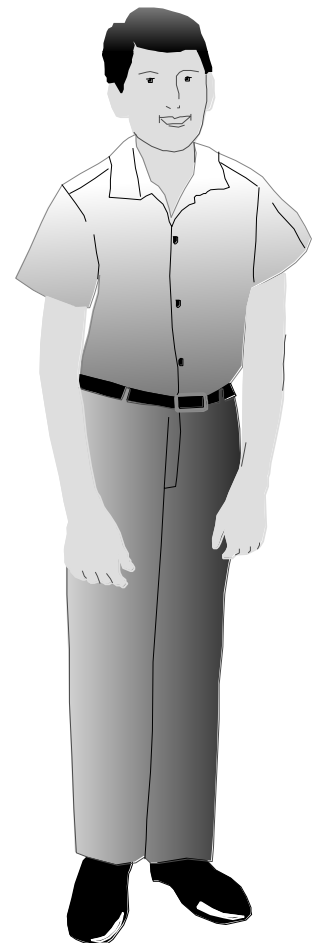

BOY'S
Age: 10-12 Years
Sizes: $3\frac{1}{2}$ - 6

TARSO MEDIUS®

Straight Last Shoes



For mild varus, in-toeing and arch support

Tarso Medius shoes are made over straight lasts. They are completely neutral, without inflare or outflare. Straight last shoes are useful in transition from Tarso Pronator or Tarso Outflare to normal shoes, or for mild pigeon toe where an outflare shoe is considered too severe.

Straight last shoes have therapeutic value where there is some slight varus or inward swing of the forefoot, which is often associated with in-toeing gait. The foot may have been previously treated – and substantially corrected – with casts and splint, or the condition may have been considered too minimal to require early treatment.

In such cases, normal shoes, many of which have some slight inflare, will do nothing to encourage the foot to correct itself, and may even aggravate the symptoms. Since the straight last shoe has no inflare, it cannot induce toeing in, and may possibly help minimize it. If the forefoot has a tendency to turn inward into varus, it will be restrained by the contour of the inner border of the straight last shoe. If the forefoot is maintained in a more nearly straight position, the child is likely to walk straighter. Although the straight last shoe has no outflare, its effect on a varus foot is that of a very mild outflare shoe. And yet, if the foot is straight, the straight last shoe is completely safe and innocuous.

There are two Tarso Medius straight lasts. One is symmetrical, neither right nor left. The other is definitely right and left, and looks almost like a normal last.

Functionally, both lasts are equally straight, as shown in the illustration. The solid outline is the symmetrical straight last. The broken line shows how the right and left straight last was derived. Some shoes made on the symmetrical straight last are detailed to match Tarso Pronator shoes, and are

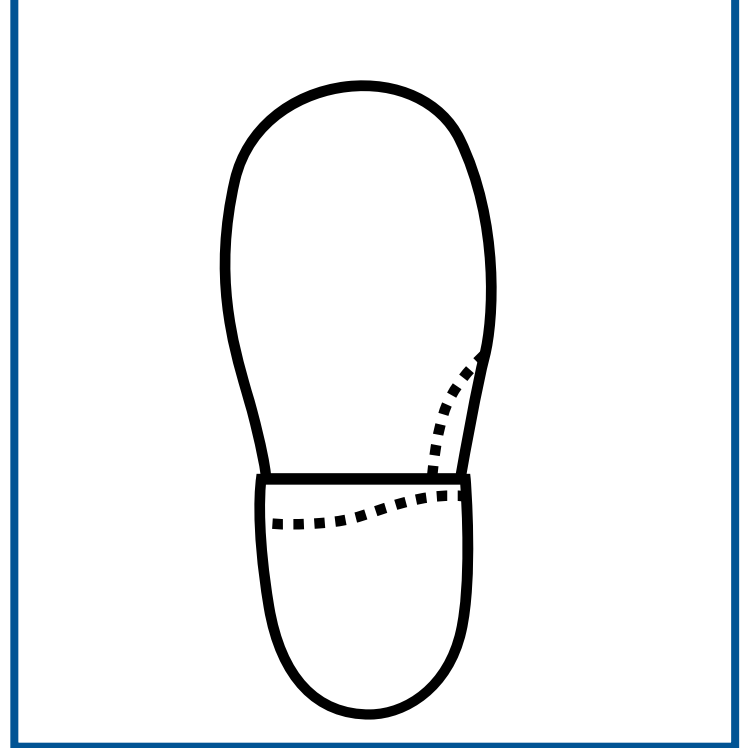

available in half pairs or mis-mated pairs. They contain no wedges or corrections. The TM2000 sneaker is made on the symmetrical straight last.

All right and left Tarso Medius shoes are made on a Goodyear welt construction, with support features; long inside counters, Thomas heels, rigid steel shanks, and inner heel wedges. They are ideal for pronated feet that toe in, and are also used as a basic prescription for mild pronation when an inflare last is not required. Right and left Tarso Medius shoes are supplied in full pairs only.

Inner heel wedges help to shift weight off the arch and over to the outer border, improving foot balance and minimizing pronation. Also, they inhibit premature wear on the inner borders of the heels, which eventually causes inward weight transfer and aggravates pronation. Inner heel wedges thus enhance and prolong the therapeutic usefulness of Thomas heel Tarso Medius shoes.

In rare instances, inner heel wedges can also cause added toe in. This usually occurs when the shoes are first worn, and disappears after the first few hours of active outdoor wear. If toe-in persists, the wedges can be removed simply and inexpensively.

Outer sole wedges of 1/8" to 3/16" can be added to help stop toeing in. However, outer sole wedges can sometimes cause arch strain. If arch protection is required, the Thomas heel Tarso Medius is preferable.

Prescribed through shoe
stores and orthopedic
appliance dealers worldwide

OUR SNEAKERS CAN
ACCOMMODATE YOUR
ORTHOTICS, A.F.O.'S, ETC.

TM2000

S E R I E S

by MARKELL

White Hi-Top with Gray Trim

TM-2000 – 5 to 10
TM-2001 – 10 1/2 to 2
TM-2010 – 2 1/2 to 6
M and W Widths

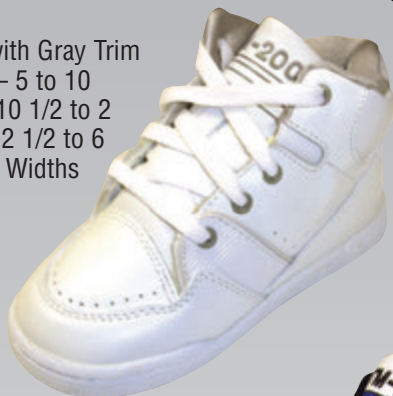

White Low with Pink Trim

TM-2004 – 5 to 10
TM-2005 – 10 1/2 to 2
TM-2015 – 2 1/2 to 6
M and W Widths



White Low with Blue Trim

TM-2002 – 5 to 10
TM-2003 – 10 1/2 to 2
TM-2013 – 2 1/2 to 6
M and W Widths



Black Hi-Top Lace
TM-2100 – 5 to 10
TM-2101 – 10 1/2 to 2
TM-2111 – 2 1/2 to 6
M and W Widths



Limited
Quantities
Available!

White Low 2-Strap

TM-2106 – 5 to 10
TM-2107 – 10 1/2 to 2
TM-2117 – 2 1/2 to 6
M and W Widths



Black Low 2-Strap

TM-2108 – 5 to 10
TM-2109 – 10 1/2 to 2
TM-2119 – 2 1/2 to 6
M and W Widths



MARKELL is committed to the best in therapeutic foot products. With an eye to the future, we have created a true orthopedic sneaker for children.

The TM 2000 Series has the following features:

- Symmetrical straight last.
- Added depth - 3/16" (5mm) deeper than our conventional straight last shoes, to accommodate orthotics, AFO's and internal modifications.
- Extended counters firm enough to provide support and stability.
- Whole and half sizes from Infants' 5 to Youths' 6.
- Widths - A choice of Medium and Wide.
- Removable cushioned insoles

SYMMETRICAL STRAIGHT LAST SHOES

TARSO MEDIUS® SHOES FOR MILD VARUS AND IN-TOEING

TARSO MEDIUS® shoes on this page are detailed to match TARSO PRONATOR®, HALF PAIRS AVAILABLE EXCEPT FOR TM-1488, TM-1489, TM-1510 and TM1511. Leather quarter linings up to size 9.

A. TAN MOC BOOT

TM-1488 Infant's 3 to 6 D & EE

TM-1489 Toddler's 6½ to 8 D & EE

Scuff Grain Apron • Spring Heel • Full Pairs Only • Cement Construction

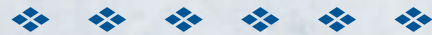

B. BLUE MOC BOOT

TM-1510 Infant's 3 to 6 D & EE

TM-1511 Toddler's 6½ to 8 D & EE

*Scuff Grain Apron • Spring Heel
Full Pairs Only • Cement Construction*



C. BROWN BOOT - PLAIN TOE

TM-1601 Infant's 4 to 6 D & EE

Spring Heel • Half Pairs Available • Cement Construction

TM-2601 Toddler's 6½ to 9 D & EE

Straight Outside Heel • Half Pairs Available • Cement Construction

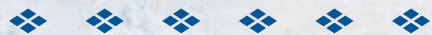

D. WHITE BOOT - PLAIN TOE

TM-1641 Infant's 2 to 6 C, D, E, EE

Spring Heel • Half Pairs Available • Cement Construction

TM-2641 Toddler's 6½ to 9 C, D, E, EE

*Straight Outside Heel • Half Pairs Available
Cement Construction*



E. BROWN BOOT - PLAIN TOE WELT

3601 Child's 9½ to 12 D & EE

4601 Youth's 12½ to 3 D & EE

4602 Boy's 3½ to 6 D & EE

Straight Outside Heel • Half Pairs Available • Welt Construction



F. WHITE BOOT - PLAIN TOE WELT

3641 Child's 9½ to 12 D & EE

*Straight Outside Heel • Half Pairs Available
Welt Construction*



STRAIGHT LAST SHOES WITH THOMAS HEELS

TARSO MEDIUS® LEFT AND RIGHT STRAIGHT LAST WITH ADDED SUPPORT

TARSO MEDIUS® shoes on this page are made on our right and left TARSO MEDIUS® straight last. They feature rigid shanks, Goodyear welt construction long inner/medial counters, inner/medial heel wedges and Thomas heels. FULL PAIRS ONLY!



A

WELT CONSTRUCTION

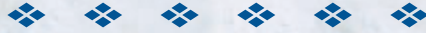

A. BLACK BOOT - PLAIN TOE

TM-3651 Infant's 3 to 6 D & EE

TM-3652 Toddler's 6½ to 8 D & EE

TM-3653 Child's 8½ to 12 D & EE

TM-3654 Youth's 12½ to 3 D & EE

TM-3655 Youth's 3½ to 6 D & EE

Thomas Heel • Leather Quarter Linings

Full Pairs Only



B



B. WHITE BOOT - MOC TOE

TM-1666 Infant's 3 to 6 C, D, E, EE

TM-2666 Toddler's 6½ to 9 C, D, E, EE

Thomas Heel • Leather Quarter Linings

Full Pairs Only



C



C. BROWN BOOT - MOC TOE

TM-277 Toddler's 5½ to 8 D & EE

Thomas Heel • Leather Quarter Linings

Full Pairs Only

STRAIGHT LAST SHOES WITH THOMAS HEELS

TARSO MEDIUS® LEFT AND RIGHT STRAIGHT LAST WITH ADDED SUPPORT

TARSO MEDIUS® shoes on this page are made on our right and left TARSO MEDIUS® straight last. They feature rigid shanks, long inner/medial counters, inner/medial heel wedges and Thomas heels. FULL PAIRS ONLY!

WELT CONSTRUCTION

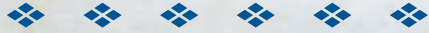

A. WHITE SANDAL

TM-812 Toddler's 5½ to 8 C, D, E

TM-813 Child's 8½ to 12 C, D, E

Thomas Heel • Leather Quarter Lining

Un-Lined Forepart • Grain Bumper Tips

Full Pairs Only

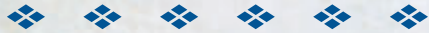

B. BLUE SANDAL

TM-512 Toddler's 5½ to 8 C, D, E

TM-513 Child's 8½ to 12 C, D, E

Thomas Heel • Leather Quarter Lining

Un-Lined Forepart • Grain Bumper Tips

Full Pairs Only



C. BLACK TWO STRAP

TM-3253 Child's 8½ to 12 C, D, E

TM-3254 Youth's 12½ to 3 C, D, E

Thomas Heel • Leather Quarter Lining

Un-Lined Forepart • Grain Bumper Tips

Full Pairs Only



STRAIGHT LAST SHOES WITH THOMAS HEELS

TARSO MEDIUS® LEFT AND RIGHT STRAIGHT LAST WITH ADDED SUPPORT

TARSO MEDIUS® shoes on this page are made on our right and left TARSO MEDIUS® straight last. They feature rigid shanks, long inner/medial counters, inner/medial heel wedges and Thomas heels. FULL PAIRS ONLY!



A

WELT CONSTRUCTION



A. BLACK & WHITE SADDLE OXFORD

TM-787	Toddler's 6 to 8	C, D, E
TM-887	Child's 8½ to 12	C, D, E
TM-987	Youth's 12½ to 3	C, D, E

Thomas Heel • Full Pairs Only



B



C

B. BROWN OXFORD

TM-836	Child's 8½ to 12	C, D, E
TM-936	Youth's 12½ to 4	C, D, E

Thomas Heel • Full Pairs Only

C. BLUE OXFORD

TM-552	Toddler's 6 to 8	D & EE
TM-553	Child's 8½ to 12	D & EE

Thomas Heel • Full Pairs Only

TM-554	Youth's 12½ to 3	D & EE
---------------	------------------	--------

Thomas Heel • Full Pairs Only

D. BLACK OXFORD

TM-843	Child's 8½ to 12	D & EE
TM-943	Youth's 12½ to 3	D & EE

Thomas Heel • Full Pairs Only

E. BLACK MOC OXFORD

TM-571	Boy's 3½ to 6	D & E
---------------	---------------	-------

Thomas Heel • Full Pairs Only



D



E

STRAIGHT LAST SHOES WITH ADDED SUPPORT

TARSO MEDIUS® LEFT AND RIGHT STRAIGHT LAST WITH MEDIAL SUPPORT

TARSO MEDIUS® shoes on this page are made on our TARSO MEDIUS right and left straight last. They feature long inner/medial counters, rigid shanks. FULL PAIRS ONLY!

WELT CONSTRUCTION

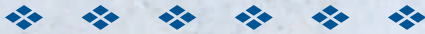

A. TAN WORK BOOT

TM-490 Child's 8½ to 12 M, W
TM-491 Youth's 12½ to 3 M, W

Lug Sole
FULL PAIRS ONLY



B. SUEDE BOOT

TM-6842 Toddler's 5½ to 8 M & W
TM-6843 Child's 8½ to 12 M & W
TM-6844 Youth's 12½ to 3 M & W
TM-6845 Boy's 3½ to 6 M & W

Composition Sole • Thomas Heel • Full Leather Lining
"W" Width accommodates inside plastic braces.
FULL PAIRS ONLY



C. MINI BUCK HIKER

TM-590 Child's 8½ to 12 M, W
TM-591 Youth's 12½ to 3 M, W

Lug Sole • Full Leather Lining
FULL PAIRS ONLY



▲ **EXTRA FULL FITTING – PERFECT FOR USE WITH PLASTIC BRACES!**

TARSO PRONATOR®



Reverse Last/Outflare Shoe - To treat varus feet and In-toeing

Tarso Pronator reverse last/outflare shoes are used for treatment of in-toeing and forefoot varus.

By outflare, we mean that the front of each shoe swings outward. This swing holds the forefoot in abduction, and turns the foot outward. Properly fitted, an outflare shoe should enable a toed-in child to walk straight – or straighter – at once, with absolutely no painful or deforming pressure on any part of the foot.

Because the Tarso Pronator last has had an outstanding reputation for safety and comfort for over eighty years, knowledgeable physicians are careful to prescribe these shoes by brand name.

Tarso Pronators have outer sole and heel wedges to help “pronate” the feet for purposes of correction.

Tarso Pronators have counters elongated on the inner sides for greater torsional rigidity.

Tarso Pronators have rigid shanks and from size 6 or 6-1/2, they have reverse Thomas heels.

Tarso Pronator shoes are designed particularly for the more rigid foot with internal torsion and forefoot varus, symptoms characteristic of both the mild club

foot and the corrected club foot. In true talipes, Tarso Pronator shoes are applied immediately after casting, with or without Denis Browne Splints and fitted as snugly as possible. This may permit earlier removal of casts, and will assure good retention of correction for as long as necessary.

Tarso Pronator open toe boots are perfect for retention of tiny infants’ feet. The open toe and detached tongue permit snugger fit. The Full Abduction last used on TP-1934, has a sharper swing - to hold the heel in valgus. The Splint Adaptor receptacles in the soles permit instant splint attachment at any time.

Since severe club foot may be unilateral, and since bilateral club foot may result in feet of different sizes, we sell Tarso Pronators in half pairs and mismatched pairs, and we supply matching straight last shoes in half pairs for use with Tarso Pronators in unilateral cases.

Prescribed through shoe stores and orthopedic appliance dealers worldwide

REVERSE LAST/ OUTFLARE SHOES

TARSO PRONATOR® WITH WEDGING
TO TREAT VARUS FEET AND IN-TOEING

TARSO PRONATOR® shoes on this page feature long inner/medial counters, rigid shanks, and outer/lateral sole and outer/lateral heel wedges from 1/8" to 3/16". Where indicated, mis-mates and matching TARSO MEDIUS® shoes are available. Leather Quarter Linings up to size 9.

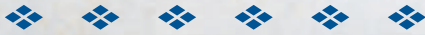

A. BLACK BOOT

TP-3611 Infant's 3 to 6 M, W

Spring Heel • Full Pairs only

Cement Construction

TP-3612 Toddler's 6½ to 9 M, W

Reverse Thomas Heel • Full Pairs Only

Cement Construction



A



B

B. WHITE BOOT

TP-5796 Infant's 0 to 3 M, W

TP-5797 Infant's 3½ to 6 M, W

Spring Heel • Half Pairs Available • Cement Construction



C

D & E



C. WHITE BOOT

TP-6797 Toddler's 6½ to 9 M, W

Reverse Thomas Heel • Half Pairs Available

Cement Construction

TP-6798 Child's 9½ to 12 M, W

Reverse Thomas Heel • Half Pairs Available

Welt Construction

D. BROWN BOOT

TP-1797 Infant's 3 to 6 M, W

Spring Heel • Half Pairs Available • Cement Construction

TP-3797 Toddler's 6½ to 9 M, W

Reverse Thomas Heel • Half Pairs Available • Cement Construction

E. BROWN BOOT

TP-4797 Child's 8½ to 12 M, W

TP-2797 Youth's 12½ to 3 M, W

TP-2798 Boy's 3½ to 5 M, W

Reverse Thomas Heel • Half Pairs Available

Welt Construction

F



F. BLACK BOOT

TP-3613 Child's 9½ to 12 M, W

TP-3614 Youth's 12½ to 3 M, W

Reverse Thomas Heel • Full Pairs Only

Welt Construction

TARSO® OPEN TOE BOOTS

Recommended for use in Ponseti Method of treating clubfoot.



A. TARSO MEDIUS® STRAIGHT LAST WITH STRAP

TM-1644 0000, 000, 00, 0, 1, 1½, 2, 2½, N & M

3, 3½, 4, 4½, 5, 5½, 6

TM-2644 6½, 7, 7½, 8 N & M

TM-2644 8½, 9, 10, 11, 12 M

Splint Adaptor Receptacles • Half Pairs Available • Cement Construction



B. TARSO MEDIUS® STRAIGHT LAST OPEN TOE & OPEN HEEL WITH STRAP

TM-1645 0000, 000, 00, 0, 1, 1½, 2, 2½, N & M

3, 3½, 4, 4½, 5, 5½, 6

0000, 000, 00, 0, 1 W

Splint Adaptor Receptacles • Full Pairs Only • Cement Construction

The built-in features in the above two models work to hold the foot firmly yet gently, with the heel seated down in the shoe. When the strap is snugly secured across the baby's instep, and the boot is laced tightly, the heel and ankle are locked in place, preventing them from slipping, rubbing, and blistering.



C. TARSO PRONATOR® FULL ABDUCTION LAST WITH STRAP

TP-1934 0000, 000, 00, 0, 1, N & M

1½, 2, 2½, 3, 3½, 4, 4½, 5

Splint Adaptor Receptacles • Half Pairs Available • Cement Construction

FITTING SUGGESTIONS

Tarso Open Toe Boots should be fitted somewhat shorter than comparable closed toe types - often a full size shorter. For your guidance, please refer to our Tarso Fitting Scale.

It shows the actual insole length of each open toe boot size.

Tarso Open Toe Boots are designed to be used to help maintain correction in babies with Clubfoot and Metatarsus Adductus. **Tarso Open Toe Boots** are made on both our **Tarso Medius** straight last and our **Tarso Pronator** full abduction last.

With the growing widespread use of the **Ponseti Method** of treating Clubfoot, Markell Shoe Company is pleased to offer two models of our Tarso Medius Straight Last Boot. These Tarso Medius Straight Last Boots have been specially constructed and provide superior comfort and support for babies' tender feet. Since newborns treated using the **Ponseti Method** are ready for shoes and a bar as early as age 6-8 weeks, we offer Tarso Medius Straight Last Boots as small as 0000 (see sizing chart).

Model 1644/2644 is a Symmetrical Straight Last Boot, made with soft tanned leathers, a well defined heel pocket, soft rolled top line and special built in padding at the back of the boot and under the tongue. These boots are made in a full range of sizes, from 0000 for newborns, up to size 9 for the older 3-4 year child.

Model 1645 is a Tarso Medius Straight Last Boot, which is both open at the toe, and has a cut-out for the heel. This newly designed boot is made with the younger clubfoot patient in mind. Young infants with atypical or hyper-sensitive feet, can sometimes experience difficulty in adjusting to boots and bars after serial casting. For these young clubfoot patients, we have designed our #1645 boot with a special cut-out in the heel, to help see that the heel is down in the correct position, to help relieve pressure, and also to better hold the foot and prevent slipping, pulling out, and blistering. Model 1645 is made in sizes 0000 to 6, and in 3 different widths, **Narrow**, **Medium**, and **Wide**, to accommodate the full range of infants with slender, normal, or pudgy feet.

Tarso Pronator style 1934 is made on a special full abduction last, which has a more pronounced curvature than our closed toe boots. The full abduction last is made to provide maximum correction for the patient with Metatarsus Adductus, and also for the corrected Clubfoot.

THE TARSO SPLINT ADAPTOR

All Open Toe Boots have two plated steel screw receptacles set flush in the bottom of each shoe so that splints or other appliances can be fastened directly to the shoe bottom without rivets or clamps. Four special screws are supplied on request with each pair of open toe boots. With economical pre-drilled Tarso Splints or Fillauer Plate Splints, attachment takes a minute or two.

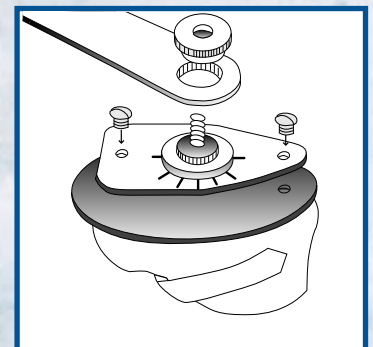

Tarso Clubfoot AFO by MARKELL

A semi-rigid AFO for use in the Ponseti Method of Clubfoot Treatment

Treatment of Idiopathic Clubfoot

The Ponseti Method has become the worldwide standard of care for the treatment of idiopathic clubfoot. It consists of a series of long leg casts and a percutaneous tenotomy, followed by an extended period of bracing to maintain correction.

The Bracing Phase

The all important bracing phase of treatment is implemented after the baby comes out of the last cast. During this phase of treatment, it is essential that the feet be maintained in corrected position, to prevent a relapse from occurring. The Ponseti Method of treatment requires that bracing of the feet in corrected position, be continued until 4 to 5 years of age.

THE TARSO CLUBFOOT AFO PROVIDES THE FOLLOWING FEATURES:

- Symmetrical shape for use on either foot.
- Semi-Rigid Construction with soft lambskin lining
- Convenient reversible hook and loop closures at top and bottom.
- Strong secure buckle and strap with dorsal pad to lock the foot down and hold it in place.
- Rigid base plates with threaded receptacles for mounting to the Dobbs Dynamic Clubfoot Bar, Horton Click Bar, or traditional Denis Browne abduction bars.

TARSO CLUBFOOT AFO MODEL # 1646 IS AVAILABLE
IN NUMBER SIZES FROM 0000 UP TO 9
SUGGESTED ICD CODE: L1930* X 2

*The final and sole responsibility for the correct coding, within established laws, rules, and standards of products, rests upon the party submitting the claim.



MARKELL SHOE CO., INCORPORATED

504 Saw Mill River Road, P.O. Box 246, Main Station, Yonkers, NY 10702 • Tel: 914-963-2258 • FAX: 914-953-9293



Tarso Clubfoot AFO Mounted on the
Dobbs Dynamic Quick Release Bar

MARKELL SHOE CO., INCORPORATED

504 Saw Mill River Road, P.O. Box 246, Main Station, Yonkers, NY 10702
Tel: 914-963-2258 • Fax: 914-953-9293 • markellshoe@optonline.net
www.markellshoe.com



Matthew B. Dobbs, M.D.
Associate Professor
Pediatric Orthopedic Surgery
Washington University
School of Medicine

Dr. Dobbs set out to increase patient compliance by making a foot abduction brace that is easier to wear, allows the child to kick and crawl, and still maintains abduction.

Parents of clubfoot children everywhere are praising his new brace, patented as the "Dobbs Bar."

Made in the USA by

MARKELL

M.J. Markell Shoe Co., Inc.
504 Saw Mill River Rd.
Yonkers, NY 10701
markellshoe@optonline.net
PH: (914) 963-2258
FAX: (914) 963-9293



A Revolution in Clubfoot Treatment



www.markellshoe.com

The New Quick Release Dobbs Bar

Now it is easier than ever to get a child in and out of his or her clubfoot brace. Just put the open-toe shoes on the child's feet and click them into place on our new Quick Release Dobbs Bar.

- Quick release mechanism allows shoes and custom AFO's to snap on and off for diapering, carseats, and high chairs.
- A variable spring reset brings the child's feet back to neutral in a resting position.
- New forefoot extensions keep the brace flat on the floor so the child can stand easily in the brace.
- Clear easy to dial degree settings with a simple turn of a screw.
- Lets children kick and move their legs independently while maintaining abduction.



- Independent motion makes it harder to pull out of shoes and reduces irritation.

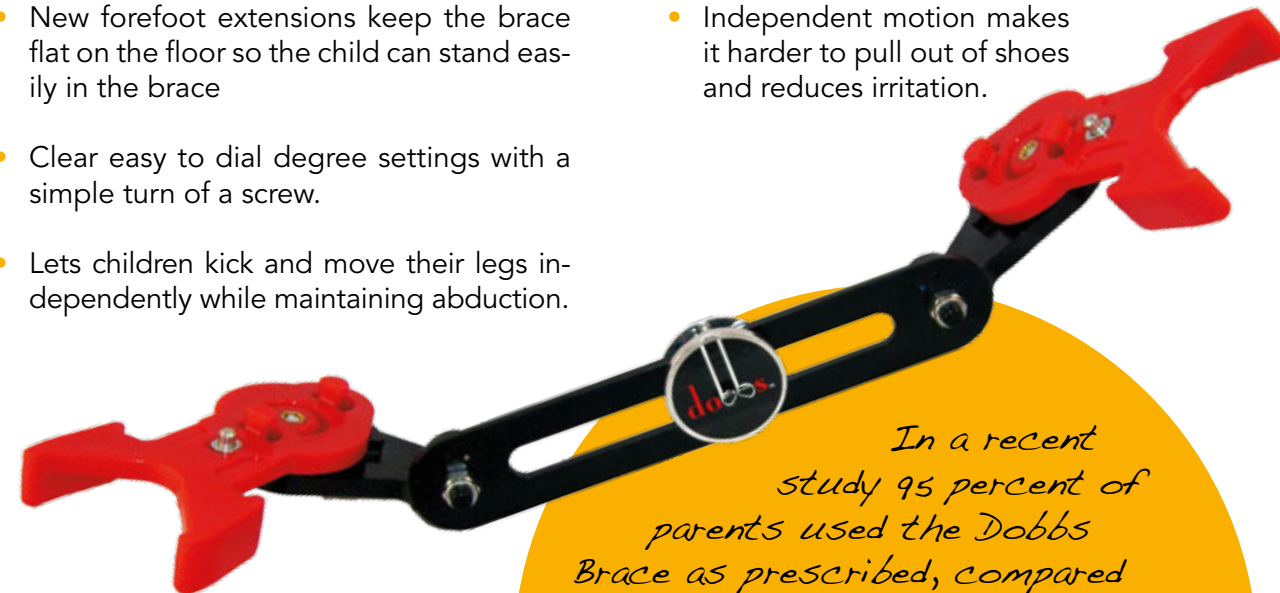

In a recent study 95 percent of parents used the Dobbs Brace as prescribed, compared to 60 percent compliance with traditional bracing.

270 AJQ Small 7-9 inch

270 AJQ Reg. 9-14 inch

Suggested L Codes: L2300x1, L2768x2

Setting Up The Dobbs Bar

- **Setting the bar width.** The Dobbs Bar should be set so that the width of the bar is equal to the shoulder width of the child. Measure the shoulder width of the child from the left outside shoulder to the right outside shoulder. Adjust the length of the Dobbs Bar so that the length of the bar is equal to your shoulder width measurement from mid-heel of the left footplate to mid-heel of the right footplate.

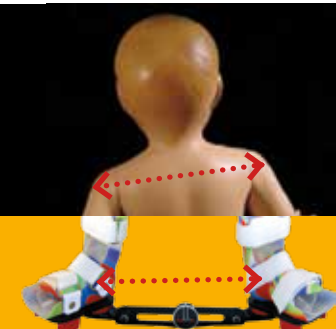

Using the included 5/32 hex key, loosen the hex head

screw(s) on the center clamp and slide the width of the bars open until they match the shoulder width of the child. Once the width is correct, retighten the hex head screw(s) to lock the bars firmly in place.

Loosen the Phillips head screw in the center of the black swivel arm and rotate the red "Y" piece outward until the pointer on the black swivel arm lines up with the correct degree setting on the red "Y" piece. Retighten the screw in order to lock in the desired angle of external rotation.

- **Setting external rotation.** The clubfoot should be set at about 60 degrees of external rotation, which should match the degree of rotation of the foot in the last cast. If the foot was externally rotated only 50 degrees in the last

cast the brace should also be at 50 degrees. A normal, non-affected foot should be fixed on the bar in about 40 degrees of external rotation.

- **Attaching the foot plate.** Attach the black foot plate to the bottom of the Markell shoes/AFO by lining up the two countersunk holes in the black foot plate with the two holes on the bottom of the shoes. Using the standard head screws provided, first tighten one screw halfway, then tighten the other screw completely. Then go back and tighten the first screw all the way.
- **Using the quick disconnect feature.** Once the foot plate is attached to the shoes, slide the black foot plate onto the two red clips and slide the foot plate forward to engage the spring plunger and lock the shoes in place. To release the shoes, pull the spring-loaded plunger while pushing the plate backwards towards the child's heel.

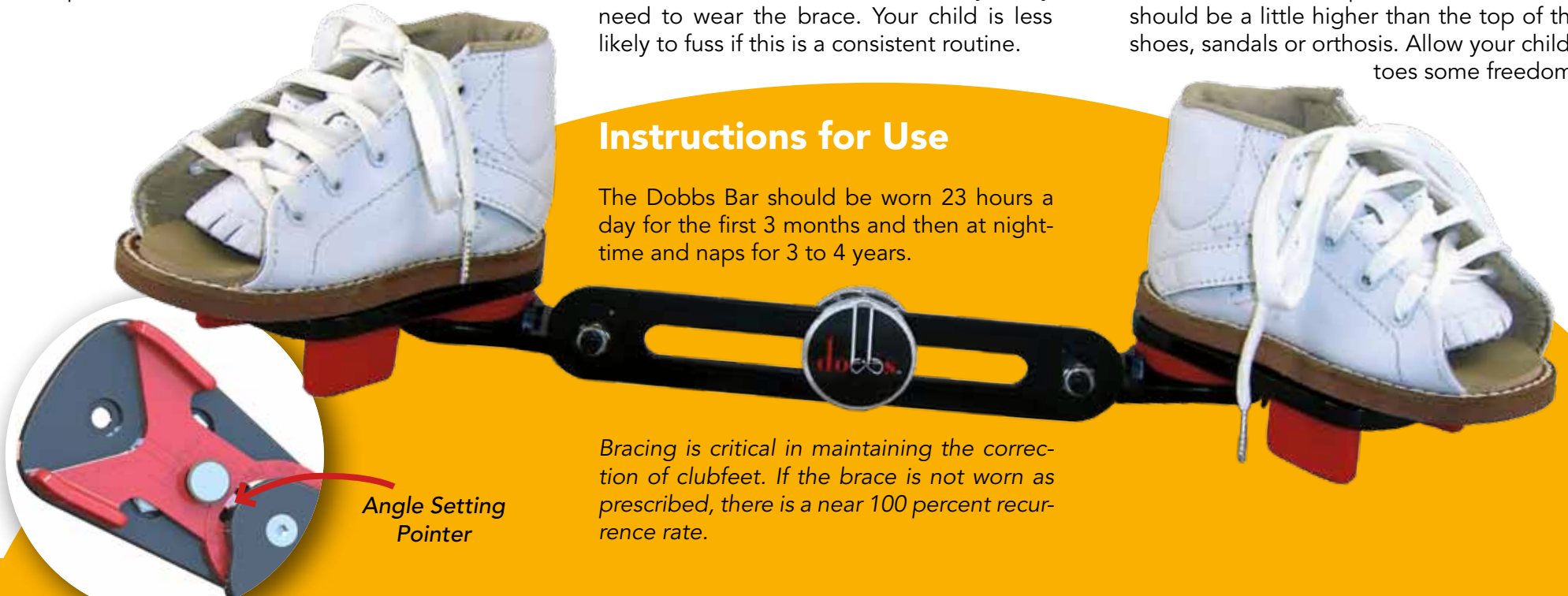

Advice for Parents

- **Play with your child in the brace.** Babies might get fussy for the first few days after receiving a brace, and will require time to adjust. Playing with your child is the key to getting over the irritability quickly. Teach your child that he/she can kick and swing the legs with the brace on by gently moving your child's legs up and down together and independently until he/she gets used to the brace.
- **Make it routine.** Children do better if you develop a fixed routine for brace wear. During the three to four years of night/naptime wear, put the brace on anytime your child goes to the "sleeping spot." They will figure out that when it is "that time of day" they need to wear the brace. Your child is less likely to fuss if this is a consistent routine.

Instructions for Use

The Dobbs Bar should be worn 23 hours a day for the first 3 months and then at nighttime and naps for 3 to 4 years.

Bracing is critical in maintaining the correction of clubfeet. If the brace is not worn as prescribed, there is a near 100 percent recurrence rate.

- **Pad the bar.** Padding the metal bar will protect you and your furniture. Padded Bar covers are available in pediatric patterns from D-Bar Enterprises. See our website for more details.

- **Check your child's feet.** It is important to check your child's feet several times a day after initiating the bracing to ensure no blisters are developing on the heel. Never use lotion on any red spots on the skin (lotion will make the problem worse). Some redness is normal with use. Bright red spots or blisters, especially on the back of the heel, usually indicate that the heel is slipping. Ensure that the heel stays down in the shoe by securing the straps and/or buckles or by talking to your orthotist about placing a heel pad in the shoe.

- **Always wear cotton socks.** Your child should always wear cotton socks under his/her shoes, sandals or plastic AFO's. The sock should be a little higher than the top of the shoes, sandals or orthosis. Allow your child's toes some freedom.

Advice for Parents

- **Check Your Child's Feet.** It is important to check your child's feet several times a day after initiating the bracing, to ensure no blisters are developing on the heel or dorsum of the foot. Consult with your doctor if blisters begin to form.
- **Make It Routine.** Children do better if you develop a fixed routine for brace wear. During the three to four years of night/naptime wear, put the brace on anytime your child goes to the "sleeping spot". They will figure out that when it is "that time of day" they need to wear the brace. Your child is less likely to fuss if this is a consistent routine
- **Always wear cotton socks.** Your child should always wear cotton socks under his/her shoes, sandals or plastic AFO's. This will protect your child's foot and prevent skin breakdowns.



Two Sizes Available
270 AJZ Small – 6" thru 9"
270 AJZ Regular – 9" thru 14"

Suggested LCodes:
L3150 & L2768 X 2



MARKELL

504 Saw Mill River Rd.
Yonkers, NY 10702-0246

Tel: 914.963.2258

Fax: 914.963.9293

markellshoe@optonline.net

www.markellshoe.com

The Parent Friendly Foot Abduction Bar



- *Easily "Clicks" on and off*
- *Makes Diapering, Dressing and Car Seats easier*
- *Adjustable width "grows with your child"*
- *Interchangeable shoe plates for 10 degree dorsiflexion*

MARKELL

M.J. Markell Shoe Co, Inc.

504 Saw Mill River Rd.

Yonkers, NY 10701

www.markellshoe.com

Powered By:  **D-Bar**
Enterprises

Easy Click Abduction Bar



Indications for Use

After your child's foot has been corrected, the EASY CLICK foot abduction brace prevents relapse by holding the foot in the corrected position.

NOTE: never apply this brace to an uncorrected foot. The brace does **not correct** clubfoot, it only holds the correction achieved by Ponseti method of treatment.

While it depends on the age of your child, typical wearing schedule is 23 hours a day for the first 3 months (allowing an hour for brace-free bathing and cuddling) and then at nighttime and naps until the child is approximately 4 years old.

Setting the Foot External Rotation:

Loosen the Phillips head screw in the bottom of the brace and rotate the red "Y" piece. Retighten the screw to lock in the desired angle of external rotation.



Setting the Bar Width

The bar should be set so the distance between the child's heels is slightly wider than the child's shoulder width. Loosen the Phillips head screw on the back of the center clamp that says "Easy Click". Slide the bars apart until the width of the bar between the child's heels is slightly wider than the child's shoulder width. Retighten the center clamp screws to lock the bar width in place. Example: if the child's shoulder width measures 8 inches, set the bar width to 8.5 inches.

Attaching the Foot Plates

The EASY CLICK comes with two sets of footplates. The first set are shaped like feet, for level or neutral mounting on the bar. The second set of foot plates are used to provide 10 degrees of dorsiflexion. Both foot plates attach to the bottom of Tarso Open Toe Boots & AFO's using the Markell splint adaptor screws provided. Tighten one screw part way, then tighten the other screw completely. Then go back and tighten the first screw all the way.



Using the Quick Disconnect

Once the foot plates are attached to the shoes, place the black footplate on the red "Y", so the clips on the red "Y" fits into the corresponding channel on the black footplate. Then slide the black footplate forward to engage the spring plunger and lock the shoes in place. To release the shoes pull back on the spring-loaded plunger while pushing the shoe plate backward-towards the child's heel.



Putting on the Easy Click

Put the child's shoes on first, making sure the heels are down and the straps and laces are snug. Then simply click them into place on the bar.



Horton Click

The new generation of foot rotation bars

The Horton click is a foot rotation bar that allows the feet to be internally or externally rotated. This bar was designed by an orthotist who understood there was a need for a more patient friendly / orthotist friendly device. The Horton Click is easier to fit on the child because you fit the shoes on independently then click them on the foot rotation bar. This allows for better positioning of the foot in the shoe which reduces the child from being able to kick the shoes off. One of the many advantages of the Horton Click is the ease of dressing the child. With just a click you can quickly remove the bar from the shoes, change the child, and click the shoes back on the bar. The Horton Click is an excellent choice for kids going through the Ponseti protocol for clubfoot treatment.

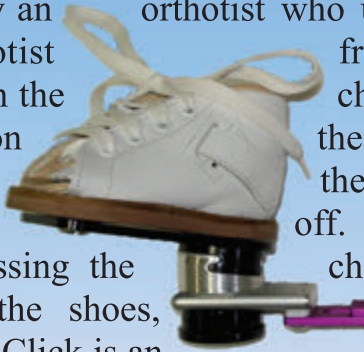

Stock No

250 AKP 68

250AKP 812

Description

Quick Release 6"-8" Adjustable Bar with 10 degree Kicker and Screws

Quick Release 8"-12" Adjustable Bar with 10 degree Kicker and Screws

Suggested L Codes: Bar L3150 Quick Release L2768



MARKELL

M.J. Markell Shoe Co., Inc. 504 Saw Mill River Rd. Yonkers, NY 10701
Tel: 914-963-2258 Fax: 914-963-9293 e-mail: markellshoe@optonline.net

Until recently, the most innovative nonsurgical treatment for clubfoot was developed in the 1950's. The treatment, developed by Dobbs's mentor at the University of Iowa, Ignacio Ponseti, MD, involves weekly casting and manipulation of the clubfoot starting soon after birth. Then, the children have traditionally worn a solid aluminum bar with shoes attached at night until about age 4 to maintain correction of the foot. The problem with that brace is that it restricts the child's movement and has the potential to cause skin blistering, which deterred many parents away from using the brace as prescribed. Using the brace less than prescribed can lead to recurrent clubfoot deformities, which may eventually require extensive surgery.

Intent on making the brace easier to tolerate for both patients and families, Dobbs designed a new dynamic brace to allow active movement, preserve muscle strength in the foot and ankle and be less restrictive to the child than the traditional version. The new brace, patented as the Dobbs Brace, has resulted in significantly improved compliance and fewer complications than the traditional brace.

In a recent study 95 percent of parents used the Dobbs Brace as prescribed, compared to 60 percent compliance with traditional bracing.



Matthew B. Dobbs, M.D.
Associate Professor
Pediatric Orthopedic Surgery
Washington University
School of Medicine



Made in the USA

Available From:
M.J. Markell Shoe Co., Inc.
504 Saw Mill River Rd.

PH: (914) 963-2258
FAX: (914) 963-9293



**A Revolution in
Clubfoot Treatment**



www.dobbsbrace.com

Setting Up The Dobbs Bar

- **Setting the bar width.** The Dobbs Bar should be set so that the width of the bar is equal to the shoulder width of the child. Measure the shoulder width of the child from the left outside shoulder to the right outside shoulder. Adjust the length of the Dobbs Bar so that the length of the bar is equal to your shoulder width measurement from mid-heel of the left footplate to mid-heel of the right foot plate. It is better to have the bar a little wider than shoulder width rather than too narrow. It is uncomfortable for the child if the bar length is too narrow.



- **Setting external rotation.** The clubfoot should be set at about 70 degrees of external rotation, which should match the degree of rotation of the foot in the last cast. If the foot was externally rotated only 50 degrees in the last cast the brace should also be at 50 degrees. A normal, non-affected foot should be fixed on the bar in about 40 degrees of external rotation. Loosen the black thumb nut and separate the serrated lock washers. Turn the foot plate until the arrow lines up with the desired degree and re-tighten the thumb nut.

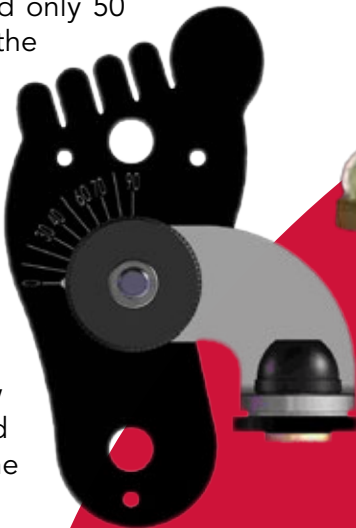

Advice for Parents

- **Play with your child in the brace.** Babies might get fussy for the first few days after receiving a brace, and will require time to adjust. Playing with your child is the key to getting over the irritability quickly. Teach your child that he/she can kick and swing the legs with the brace on by gently moving your child's legs up and down together and independently until he/she gets used to the brace.
- **Make it routine.** Children do better if you develop a fixed routine for brace wear. During the three to four years of night/naptime wear, put the brace on anytime your child goes to the "sleeping spot." They will figure out that when it is "that time of day" they need to wear the brace. Your child is less likely to fuss if this is a constant routine.



- **Pad the bar.** Padding the metal bar will protect you and your furniture. Padded Bar covers are available in pediatric patterns from D-Bar Enterprises. See our website for more details.
- **Check your child's feet.** It is important to check your child's feet several times a day after initiating the bracing to ensure no blisters are developing on the heel. Never use lotion on any red spots on the skin (lotion will make the problem worse). Some redness is normal with use. Bright red spots or blisters, especially on the back of the heel, usually indicate that the heel is slipping. Ensure that the heel stays down in the shoe by securing the straps and/or buckles or by talking to your orthotist about placing a heel pad in the shoe.
- **Always wear cotton socks.** Your child should always wear cotton socks under his/her shoes, sandals or plastic AFO's. The sock should be a little higher than the top of the shoes, sandals or orthosis. Allow your child's toes some freedom.

Instructions for Use

The Dobbs Bar should be worn 23 hours a day for the first 3 months and then at nighttime and naps for 3 to 4 years.

Bracing is critical in maintaining the correction of clubfeet. If the brace is not worn as prescribed, there is a near 100 percent recurrence rate.





Matthew B. Dobbs, M.D.
Associate Professor
Pediatric Orthopedic Surgery
Washington University
School of Medicine

Dr. Dobbs set out to increase patient compliance by making a foot abduction brace that is easier to wear, allows the child to kick and crawl, and still maintains abduction.

Parents of clubfoot children everywhere are praising his new brace, patented as the "Dobbs Bar."

MARKELL

M.J. Markell Shoe Co.
P.O. Box 246 Main Station
Yonkers, NY 10702-0246
USA

PH: (914) 963-2258 | FAX: (914) 963-9293
www.markellshoe.com



New Mitchell
**SPRING ASSIST
DOBBS BAR**



www.dobbsbrace.com

**A Revolution in
Clubfoot Treatment**

**The New Mitchell Spring-Assisted
Dobbs Bar**

- Quick release mechanism allows Ponseti® AFO's to slide on and off for diapering, carseats, and high chairs.
- The spring assist provides a dynamic stretch on the calf allowing patients to build calf muscle strength while moving and playing in the brace which helps mitigate the calf atrophy commonly seen in clubfoot patients.
- A spring reset brings the child's feet back to neutral in a resting position. The spring maintains an active dorsiflexion stretch while still allowing the child to play and crawl in the brace.
- Clear easy dial degree settings with a simple turn of a screw.



- Let's children kick and move their legs independently while maintaining abduction.
- Independent motion makes it harder to pull out of AFO's and reduces irritation.

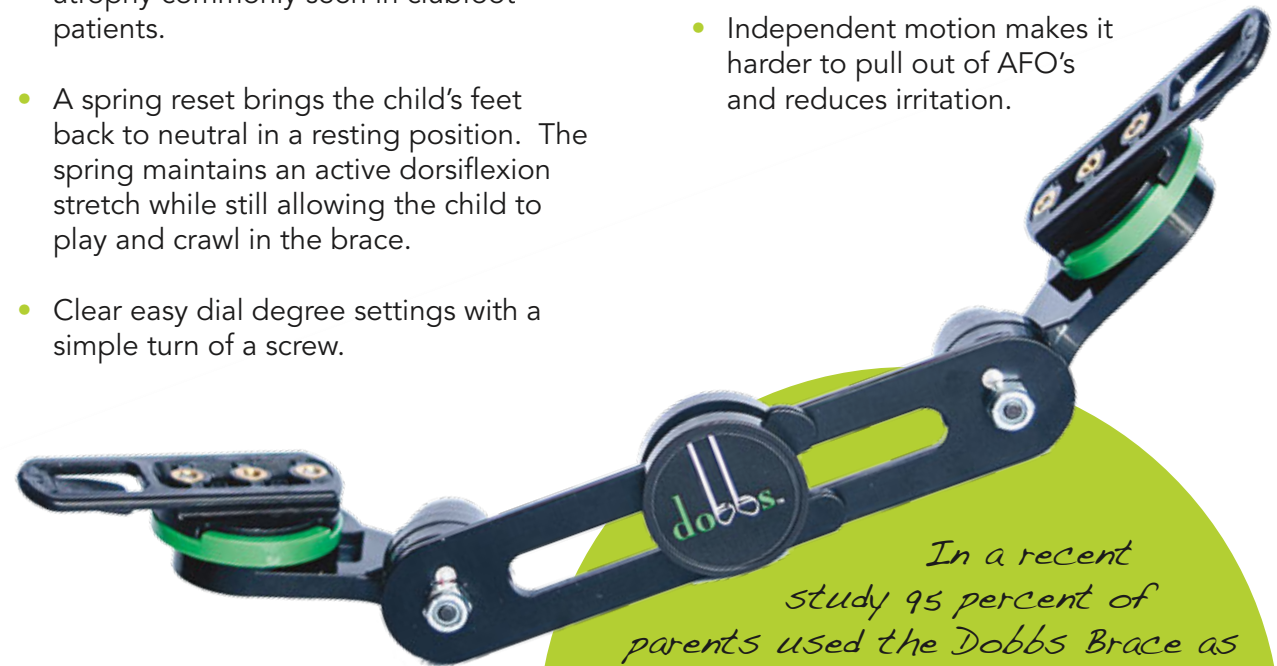

In a recent study 95 percent of parents used the Dobbs Brace as prescribed, compared to 60 percent compliance with traditional bracing.

Setting Up The Dobbs Bar

- **Setting the bar width.** The Dobbs Bar should be set so that the width of the bar is equal to the shoulder width of the child. Measure the shoulder width of the child from the left outside shoulder to the right outside shoulder. Adjust the length of the Dobbs Bar so that the length of the bar

is equal to your shoulder width measurement from mid-heel of the left footplate to mid-heel of the right foot plate.

Using a Phillips screwdriver, loosen the flat head

screw(s) on the center clamp and slide the width of the bars open until they match the shoulder width of the child. Once the width is correct, retighten the Phillips head screw(s) to lock the bars firmly in place.

- **Setting external rotation.** Loosen the Phillips head screw in the center of the black swivel arm and rotate the green piece outward until the pointer on the black swivel arm lines up with the correct degree setting on the green piece. Retighten the screw in order to lock in the desired angle of external rotation.

The clubfoot should be set at about 60-70 degrees of external rotation, which should match the degree of rotation of the foot

in the last cast. If the foot was externally rotated only 60 degrees in the last cast the brace should also be at 60 degrees. A normal, non-affected foot should be fixed on the bar in about 30-40 degrees of external rotation.

- **Attaching the AFO's.** Once the angle of external rotation is set by your physician, therapist or orthotist, simply slide the black piece labeled "PUSH" into the recessed channel on the bottom of the AFO. The piece labeled "PUSH" will pop up and lock the AFO in place. To take the AFO off, press firmly on the part labeled "PUSH" while pulling backwards on the bar until it slides free of the channel.



Advice for Parents

- **Play with your child in the brace.** Babies might get fussy for the first few days after receiving a brace, and will require time to adjust. Playing with your child is the key to getting over the irritability quickly. Teach your child that he/she can kick and swing the legs with the brace on by gently moving your child's legs up and down together and independently until he/she gets used to the brace.

- **Make it routine.** Children do better if you develop a fixed routine for brace wear. During the three to four years of night/nap-time wear, put the brace on anytime your child goes to the "sleeping spot." They will figure out that when it is "that time of day" they need to wear the brace. Your child is less likely to fuss if this is a consistent routine.

- **Pad the bar.** Padding the metal bar will protect you and your furniture. Padded Bar

covers are available in pediatric patterns from D-Bar Enterprises. See our website for more details.

- **Check your child's feet.** It is important to check your child's feet several times a day after initiating the bracing to ensure no blisters are developing on the heel. Never use lotion on any red spots on the skin (lotion will make the problem worse). Some redness is normal with use. Bright red spots or blisters, especially on the back of the heel, usually indicate that the heel is slipping. Ensure that the heel stays down in the shoe by securing the straps and/or buckles or by talking to your orthotist about placing a heel pad in the shoe.

- **Always wear cotton socks.** Your child should always wear cotton socks under his/her shoes, sandals or plastic AFO's. The sock should be a little higher than the top of the shoes, sandals or orthosis. Allow your child's toes some freedom.

Instructions for Use

The Dobbs Bar should be worn 23 hours a day for the first 3 months and then at night-time and naps for 3 to 4 years. *Bracing is critical in maintaining the correction of clubfeet. If the brace is not worn as prescribed, there is a near 100 percent recurrence rate.*



DENIS BROWNE SPLINTS

Recommended for use in Ponseti Method of treating clubfoot.

The **Ponseti Method** calls for "foot abduction bracing" after the deformities have been corrected by serial casting and tenotomy. The "Foot Abduction Brace" consists of Markell Open Toe Straight Last Boots mounted on a Denis Browne Bar Splint. Correction is maintained by holding both feet in an abducted position, **shoulder width apart**, in boots which are mounted to a splint with foot plates. Markell offers Denis Browne Splints with foot plates in either fixed or adjustable bar lengths. All of the Denis Browne Splints with foot plates come with two pre-drilled holes in the plate for easy mounting to the screw receptacles in our open toe boots, using our splint adaptor screws.

A. STANDARD SPLINT

140-DB - Denis Browne Type - With foot plates. Made of quality 24ST aluminum Alloy. Gold anodized bar. Bar sizes: 6,7,8,9,10, and 12.

All foot plates have two large pre-drilled holes for splint adaptor screws, and have protractors ruled in 5 degree increments and clearly labeled with the most widely used settings of 45 and 70 degrees.

B. TARSO ADJUSTABLE

BAR SPLINT WITH PLATES

240 AJP **Medium:** 6 to 10 Inches of heel separation in three steps

Large: 10-14 Inches of heel separation in three steps

Plates and 1 inch knurled nuts are the same as for 140-DB Standard Splint.

C. 165 FPL FILLAUER PLATE SPLINTS

Red anodized aluminum bar.

BAR LENGTHS: 4, 5, 6, 7, 8, 9, 10, 12, 14, 16 inches.

FILLAUER PARTS: Fillauer bars, clamps, hex nuts and plates are available separately. They do not interchange with Tarso Splint parts.

D. 265 AJP FILLAUER

ADJUSTABLE PLATE SPLINTS

Red anodized aluminum bar.

BAR LENGTHS: 7" to 11" and 9 to 15".

FILLAUER PARTS: Fillauer bars, clamps, hex nuts, barrel clamps, allen wrenches, and plates are available separately. They do not interchange with Tarso Splint parts.

E. 164 FIL FILLAUER CLAMP SPLINTS

Red anodized aluminum bar.

BAR LENGTHS: 4, 5, 6, 7, 8, 9, 10, 12, 14, 16 inches.

F. 264 AJC FILLAUER

ADJUSTABLE CLAMP SPLINTS

Red anodized aluminum bar.

BAR LENGTHS: 7" to 11" and 9 to 15".

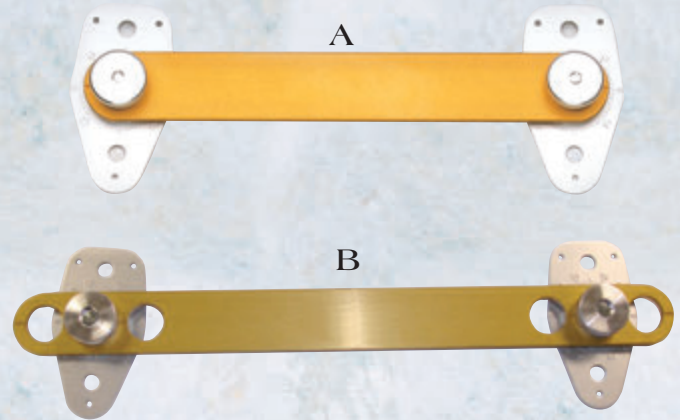

The newly re-designed Tarso Adjustable Bar Splints provide the three most commonly prescribed settings in each of two age/size ranges. Heel separation is set precisely to the optimum position for the individual patient, and may be reset during treatment. Splint stocking is simplified, since two sizes satisfy most prescriptions.

Note: The settings on each adjustable bar denote inches of heel separation with the feet set at 45-70 degrees of external rotation.

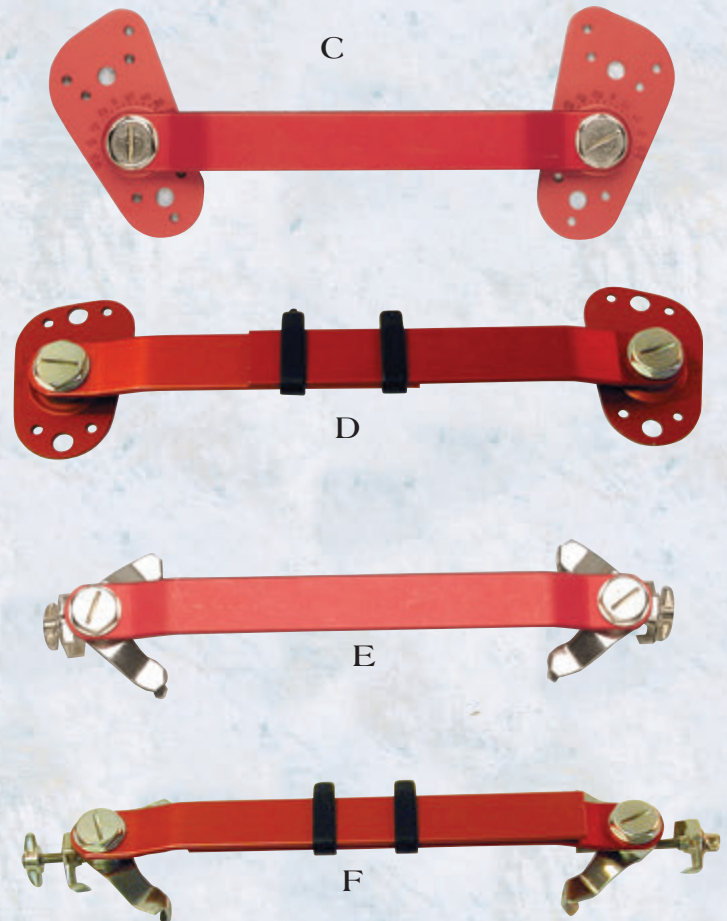

TARSO BRACE BOOTS

TARSO MEDIUS® SURGICAL BOOT

TARSO MEDIUS® Surgical boots are made on the symmetrical TARSO MEDIUS® straight last with symmetrical patterns, regular counters and steel shanks. There are no rights or lefts on these styles. The boys' and men's black surgical boots #702 and #703 are made on a normal, slightly inflated right and left last with regular counters, rigid right and left shanks and full tongues. Except where noted, half pairs are available. All Tarso Surgical Boots are made on a Goodyear welt construction and can be easily modified for braces and appliances.



WELT CONSTRUCTION

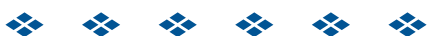

A. TARSO® BLACK BOOT BOYS' AND MEN'S

702	Boys	3½ to 7	Medium
703	Mens	7½ to 12	Medium

*Regular Right and Left Last • Straight outside heel
HALF PAIRS AVAILABLE.*

A

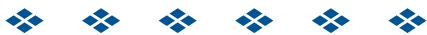

B. TARSO® MEDIUS BROWN BOOT

TM-5011	Infant's	3½ to 6	Medium
TM-5012	Toddler's	6½ to 9	Medium
TM-5013	Child's	9½ to 12	Medium
TM-5014	Youth's	12½ to 3	Medium
TM-502	Boy's/Girls	3½ to 6	Medium
TM-503	Adult's	6½ to 8	Medium

Straight outside heel. HALF PAIRS AVAILABLE.

B



TARSO BRACE BOOTS®

WELT CONSTRUCTION

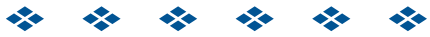

C. TARSO® MEDIUS BLACK BOOT

TM-3011	Infant's	3½ to 6	Wide
TM-3012	Toddler's	6½ to 9	Wide
TM-3013	Child's	9½ to 12	Wide
TM-3014	Youth's	12½ to 3	Wide

Straight outside heel. HALF PAIRS AVAILABLE.



C



D



D. TARSO® MEDIUS WHITE BOOT

TM-6011	Infant's	3½ to 6	Medium
TM-6012	Toddler's	6½ to 9	Medium
TM-6013	Child's	9½ to 12	Medium
TM-6014	Youth's	12½ to 3	Medium
TM-602	Boy's/Girl's	3½ to 6	Medium

Straight outside heel. HALF PAIRS AVAILABLE.

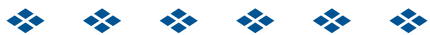

E. SUEDE SURGICAL BOOT

TM-6842	Toddler's	5½ to 8	M & W
TM-6843	Child's	8½ to 12	M & W
TM-6844	Youth's	12½ to 3	M & W
TM-6845	Boy's	3½ to 6	M & W

Composition sole • Thomas Heel • Full Leather Lining
"W" Width accommodates inside plastic braces.
FULL PAIRS ONLY.



E

▲ EXTRA FULL
FITTING - PERFECT
FOR USE WITH
PLASTIC BRACES!

TARSO SUPINATOR®

Inflare shoes for postural treatment of pronation and heel valgus

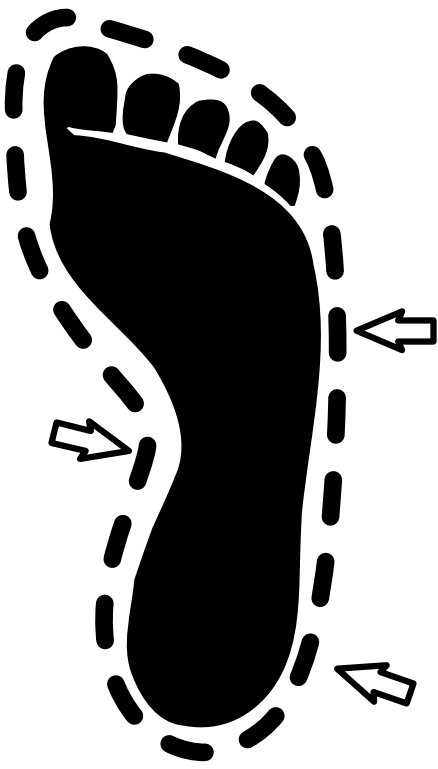

Pronation can be most effectively treated from ages two to five – when the bones of the feet are developing. Pronation is treated when it is causing trouble, or COULD cause trouble in the future.

Some indications for treatment of pronation are:

- ▶ **SEVERE PLANO VALGUS SYMPTOMS** – marked misalignment of foot, ankle and leg, and a toe out gait.
- ▶ **STUMBLING AND FALLING** because of externally rotated feet and legs.
- ▶ **COMPLAINTS OF PAIN AND FATIGUE** of feet and legs – chronic refusal to walk.
- ▶ **BACK PROBLEMS** associated with aggravated pronation.
- ▶ **HISTORY OF CHRONIC ILLNESS**, poor muscle tone or obesity.

Effective treatment requires postural correction – by which we mean taking measures which will immediately improve the posture and alignment of the feet and legs.

While complete and permanent reversal of severe flat feet can seldom be achieved without intensive exercise, lasting improvements in posture and function can be achieved if postural correction is maintained consistently for a year or more during the critical growing period from two to five.

Postural correction must start with correction of heel valgus – the turned out and tilted in heel position characteristic of pronated feet. The heel is used as a lever to raise the arch and align the foot with a minimum of direct pressure on the arch.

The most effective and comfortable therapy for heel valgus is a medially wedged inflare shoe – a shoe that curves inward so that it will “supinate” or swing in the back part of the foot and hold it in a slightly varus position.

When the heel is swung in, the legs and ankles will align and straighten. An arch will form and when the child walks, external rotation will be eliminated or greatly reduced – immediately!

Flexible flat feet conform readily to the shape of the inflare shoe and patients feel an agreeable sense of firmness and security.

The Tarso Supinator® is a wedged inflare shoe developed over sixty years ago for postural correction of pronation. It is well known and widely used. Under medical supervision, it is an effective, safe and reliable prescription which should be considered whenever pronation is serious enough to require medical intervention.

Prescribed through shoe stores and orthopedic appliance dealers worldwide

INFLARE SHOES FOR PRONATED/FLAT FEET

TARSO SUPINATOR® Inflare shoes feature inflare last, long inner/medial counters, rigid shanks and Thomas heels with inner/medial heel wedges from 1/8" to 3/16".
FULL PAIRS ONLY.

CEMENT CONSTRUCTION

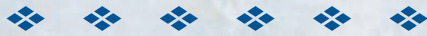

A. BROWN PLAIN TOE BOOT

TS-1377 Infant's 4 to 6 D, EE

Spring Heel • Full Pairs Only

TS-4377 Toddler's 6½ to 9 D, EE

Thomas Heel • Leather Quarter Linings

Full Pairs Only • Cement Construction



A



B. BLACK BOOT

TS-3661 Infant's 3 to 6 D, EE

Spring Heel • Full Pairs Only

TS-3662 Toddler's 6½ to 9 D, EE

Thomas Heel • Leather Quarter Linings

Full Pairs Only • Cement Construction



B

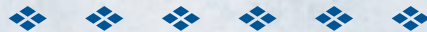

C. WHITE BOOT

TS-3377 Infant's 2 to 6 D, EE

Spring Heel • Full Pairs Only

TS-6377 Toddler's 6½ to 9 D, EE

Thomas Heel • Full Pairs Only

Leather Quarter Linings • Cement Construction



C

FOOT SUPPORTS

HEEL SEAT SIZE CHART

HEEL SEAT SIZE	SHOE SIZE COMPARISON	
5	3, 4, 5	INFANT
6	4, 5, 6	
7	6, 7, 8	
8	8, 9, 10	
9	10, 11, 12	CHILD
10	12, 13, 1	
11	1, 2, 3	YOUTH
12	2, 3, 4	
13	3, 4, 5	
14	4, 5, 6, 7	ADULT
15	5, 6, 7, 8	
16	7, 8, 9, 10	
17	9, 10, 11, 12	
18	11, 12, 13, 14	
19	12, 13, 14, 15	

**** NOTE:** For wider feet choose a larger Heel Seat Size

**** NOTE:** Variance in heel sizes requires proper fitting for corrective effect.

A. FOOT REST HEEL SEAT

176 HS - Semi-rigid plastic heel cups control pronation by holding heel upright. Wear in any firm shoe. Cup Sizes 5-19 fit all shoe sizes from Infant's 3 to Men's 15. Full Pairs Only.

B. SNEAKER MOLDS

Rigid pressed leather supports for sneakers and other flexible footwear. Scaphoid and cuboid flanges.

135-SM Children's 6 - 12
136-SM Youth's 13 - 3
137-SM Boys' 4 - 7 and Women's 4 - 10
138-SM Men's 8 - 12
139-SM Men's 13 - 14

Full pairs and full sizes only.

C. SCAPHOID PADS

Scaphoid pads with buffed edges and leather covers.

122-SCP Children's 4 - 12
123-SCP Youth's 13 - 3
124-SCP Boys' 4 - 6 and Women's 4 - 12
125-SCP Men's 7 - 12

Full pairs and full sizes only.

D. THOMAS HEELS

Made with bases and inner wedges attached. Wedges may be removed. Supplied in full pairs.

105TH, 106TH, 107TH
 Sizes: 16, 18, 20, 22, 23, 25, 27, 29

E. FLEXIFLY ORTHOTICS

Modified Schaefer polypropylene heel to ball foot support.

190-FLX - Children's Sizes 4 - 5, 6 - 7, 8 - 9, 10 - 10½, 11 - 11½, 12 - 13, 1 - 2, 3 - 4
191-FLX - Men's Sizes 5 - 13 & Women's Sizes 4 - 11

F. ANTI-SHOX

SPUR HEEL CRADLE

111HCR New! Silicone Mixture!

- Cavity under the heel removes pressure
- Cushions and soothes tender heels
- Relieves heel inflammation
- Helps with heel spurs

Small - Fits Women's 4-8
 Medium - Fits Women's 9+ or Men's 7-10
 Large - Fits Men's 11+
Sold in pairs

G. ANTI-SHOX HEEL CUPS

110 HC - Rubber Anti-Shox heel cups.

One size fits all. Sold in pairs.

H. TULI'S HEEL CUPS

150 TU - Shock Absorbers for your body. Relieves spur, arch, and lower limb pain on heel strike. Available in Regular (under 175 lbs.) and Large Size (over 175 lbs.). Sold in pairs. **ASK FOR PRICING ON THE FULL RANGE OF TULI PRODUCTS.**

FINDINGS/ACCESSORIES

A. 100-RITZ- RITZ STICK

A reliable measuring device for shoe fitting.

The **STANDARD** scale (printed in smaller type) is suggested for closed toe **TARSO** styles. We suggest trying a full size smaller than the **STANDARD** scale measurement when fitting **TARSO** open toe styles.

The **CUSTOM** Scale (printed in large type) is suggested for Styles 702 and 703 Boys' and Men's Surgical Boots – and for most boys' and men's shoes.



B. BRANNOCK DEVICES

100BRNK

JUNIOR MODEL: For non-weight bearing measurement Infant Size 0 to Misses Size 5.

WOMEN'S MODEL: Calibrated for fitting women's fashion footwear. No need to adjust the size.

MEN'S MODEL: Calibrated for fitting Mobility Shoes and other men's footwear. Width scale is calibrated to correctly fit wider men's feet.

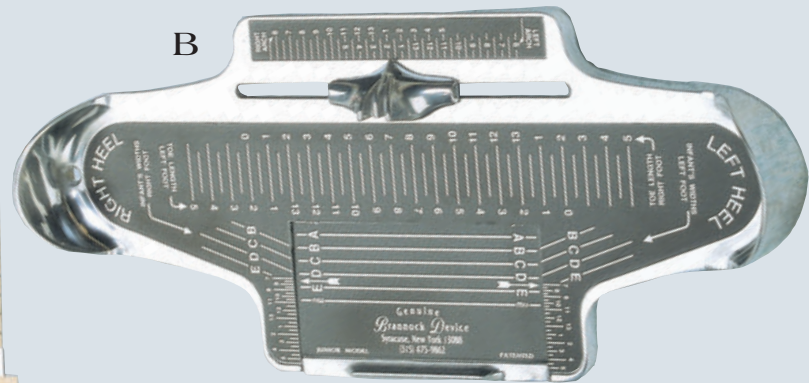

C. TARSO FITTING SCALE FOR MEASURING OPEN-TOE BOOTS

100FIT

A specially designed clear plastic template **ONLY** for use when measuring open-toe boots, shows the insole length of each open toe boot. Place heel on base line and find Markell Size closest to big toe. Go up to next size line to allow proper growth room.

C

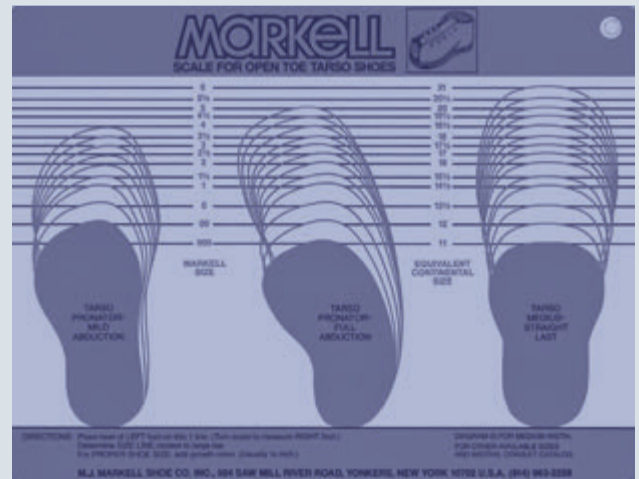

D. SHOE ADHESIVE

112 SA - Shoe Adhesive • All Purpose

Quart Cans With Brush • Heavy Duty

THINNER

For Thinning All Purpose Cement

D



E. HEEL PADS

117-HP Made of 1/4" felt. Sizes: Small (1 - 2) and Medium (3 - 4). Sold in dozen pair packages.



F. TONGUE PADS

114-TG Felt with Adhesive backing. Medium (#2) and Large (#3). Sold in dozen pair packages.

FOAMART FOOT IMPRESSION KITS AVAILABLE



Aetrex Performance Footwear combines the latest developments in pedorthics with state-of-the-art shoe design. More and more individuals across the globe are experiencing

the comfort and performance of Aetrex, wearing styles including runners, and casual walkers.

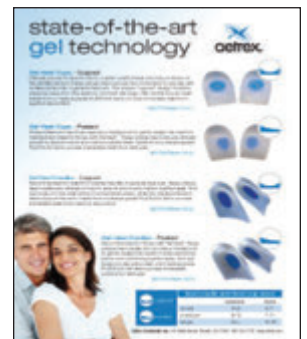
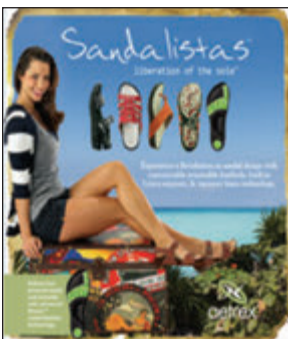

We distribute the complete line of Aetrex, Apex, and Lynco products. Call and request a set of Aetrex footwear and product catalogs.

PULMAN INTERNATIONAL® COMFORT SHOES

STYLISH, WASHABLE AND COMFORTABLE SHOES
FOR CONVALESCENCE AND REHABILITATION

Pulman shoes are designed for men and women. Strong enough for the street. Comfortable as house slippers. Perfect for most adult patients, at home - or in chronic care facilities.

An ingenious hidden feature makes Pulman International Shoes remarkably accommodative. The whole front of the shoe, plug and instep, lifts and opens as a unit. With the foot in place, the front closes and fastens securely in whatever position fits best. The fastening is a hooked material under the plug, which sticks anywhere on the outer surface of the shoe. Also, there is a zippered backseam, which opens, closes and locks - at any point - to accommodate swelling.

Uppers are fabric; a laminated fully lined velour that stretches and breathes. There are no counters or boxtoes. The upper retains its shape without them. Soles of molded polyurethane are flexible, long wearing and totally non-skid. The soft foam insoles have terry textured facing and are removable for washing. Workmanship is superb. Shoes and insoles are completely machine washable in warm water. Shoe trees are supplied for perfect 24 hour drying. Tough enough to outlast any conventional hospital shoe, Pulman International Shoes cost less than most adult comfort footwear.



A

A. 904 High Black Available in European Sizes 36 - 48.
Fits Womens 5 through Men's 15. See Pulman to American Size Chart Below



B

**FULL
PAIRS
ONLY**

B. 902 Low Black Available in European Sizes 36 - 48.
Fits Womens 5 through Men's 15. See Pulman to American Size Chart Below

**C. NEW PULMAN EXTRA DEEP SANDAL®
907 SDL Gray** Available in European Sizes 36 - 48.
Fits Womens 5 through Men's 15. See chart above.

The new Pulman Extra Deep Sandal offers the best features of style, comfort and accommodation in a lightweight sandal. Made from the same high-quality velour material as the other Pulman shoes, the Extra Deep Sandal is also machine washable. This soft sandal uses the new, lighter, flexible polyurethane outsoles and is made with the new wider lasted sole base with a thick, removable, terry-faced insole.



C

902, 904 & 907 SIZE CHART

Pulman Size	36	37	38	39	40	41	42	43	44	45	46	47	48
Womens Size	5	6	7	8	9	10	11	12	13	-	-	-	-
Men's Size	-	-	5	6	7	8	9	10	11	12	13	14	15

**D. NEW MODEL PULMAN REHAB SANDAL®
905 SDL Navy** Sizes: Small, Medium, Large, Extra Large. See chart above.
Full Pairs Only

Now from Markell, a new addition to the Pulman group of washable accommodative footwear. The Pulman Rehab Sandal® designed with the special needs of the post-surgical patient in mind. The special cutaway front allows freedom of movement and space for patients after bunion surgery, as well as those with other hallux deformities.

Pulman Rehab Sandals® are made on a broader, deepened last which will accommodate dressings and bandages more easily than any healing sandal on the market. In addition to the soft feel velour upper material, the Rehab Sandal® is made with a new deep cushioned footbed to further absorb shock and cradle the foot after surgery. A reinforced notched heel counter adds stability. Turn over our Rehab Sandal® and you will see our new ultra-light ripple-rocker outsole, which cushions and supports while providing great ease of movement.



D

905 SIZE CHART

SANDAL SIZE	SMALL	MEDIUM	LARGE	X-LARGE
Euro Size	35-37	38-40	41-43	44-46
Womens Size	4-6	7-9	10-12	
Men's Size	-	5-7	8-10	11-13

POST-OPERATIVE SURGICAL SHOES AND BOOTS



A

A. THE MEDICAL SURGICAL SHOE

25DRSM In Navy & Black Mens: S, M, L, XL

30DRSW In Navy & Black Women's: S, M, L

30DRSW In Navy & Black Pediatric - One Size Only

• Nylon mesh upper contours to foot • Adjustable closures accommodate bulky dressings and provide compression • Padded Dorsal Flap • Tricot Foam Lining • Reinforced heel counter eliminates slipping and lateral motion • Tapered Heel permits proper heel strike • Inner sole forms to contours of foot • EVA midsole with 15 degree declination angle absorbs shock • Non-skid outsole

MEDICAL SURGICAL		SHOE SIZES
Mens:	SM	6-8
	MD	8-1/2 - 10
	LG	10-1/2 - 12
	XLG	12-1/2 - 14
Womens:	SM	4 - 6
	MD	6-1/2 - 8
	LG	8-1/2 - 10
Pediatric:		12 - 1

B. ORTHOWEDGE HEALING SHOES

Finally – A shoe that elevates and protects the forefoot!

35DROW Available in Black

The new and improved OrthoWedge® Healing Shoe offers the most advanced design for reducing pressure on the forefoot while allowing patients to maintain their mobility. Thanks to a newly designed shorter wedge, an even larger portion of the forefoot is offloaded. This allows ulcerations under the metatarsal heads and toes to heal faster. OrthoWedge is the perfect choice for use after surgical procedures. Sizes: XS, S, M, L, XL



B

DARCO SHOES
Are sold and priced
singly - not as pairs

WE DISTRIBUTE THE COMPLETE
LINE OF DARCO PRODUCTS.

C. HEELWEDGE HEALING SHOES

45DRHW Available in Black

The new and improved HeelWedge® Healing Shoe offers the most advanced design for reducing pressure on the heel while allowing patients to maintain their mobility. HeelWedge is the perfect choice for use after surgical procedures. Sizes: XS, S, M, L, XL



C

D. THE DARCO A.P.B.™ HI

20-APB Classic black post-operative shoe with unisex styling.

Sizes: XS, S, M, L, XL.

Strapless forefoot closure • Only 5 Sizes to Stock • Non-skid walking sole
• MetaShank™ Support • Closed Toe Design • Breathable Upper • Ankle Strap



D

E. DARCO SLIMLINE™ CAST BOOTS

A new cast boot specially lasted for fiberglass casts
... and built on a double rocker sole for easy ambulation.

40-DRCB The SlimLine boot is built around a narrow last so it fits better than the old plaster cast boots, and with our stretchable upper, a custom fit is possible everytime! Adult SlimLine cast boots come in **Black only**.
Sizes: XS, S, M, L, XL

40-DRCB Pediatric Sizes in Navy Blue only:

Ped. Small: Fits Shoe Sizes 8 - 10-1/2

Ped. Medium: Fits Shoe Sizes 11 - 1-1/2

Ped. Large: Fits Shoe sizes 2-4

**Adult Sizing For OrthoWedge,
Heelwedge & APB and SlimLine Boots**

X-Small	Women's	3-5
Small	Women's	5-1/2 - 8
Medium	Women's	8-1/2 - 10
	Men's	6 - 8
Large	Men's	8-1/2 - 11
X-Large	Men's	11-1/2 - 14

E



Gentle Step™

Full Pairs Only

The ultimate comfort in an extra-depth shoe from Darco.



Firm, extended heel counter for rear foot stability

Constructed with special materials to reduce friction and pressure

Toe upper made of soft, elastic material -- accommodates deformities and reduces pressure from edema

Toe area of sole is smooth to prevent tripping on carpets for patients with shuffling gait

Molded outsole allows extra-depth yet maintains normal profile

Both the GentleStep™ shoes and the GentleStep Orthoses™ insoles meet all requirements of the Medicare Therapeutic Shoe Bill.

Gentle Step Shoe
55DRGS in Black

Womens Sizes | 5.5 - 16, M, W, XW
Mens Sizes | 4 - 14.5, M, W, XW

GentleStep Orthoses™
Therapeutic Insoles



- anti-microbial cotton cover
- low-density EVA
- high-density urethane foam
- medium-density EVA

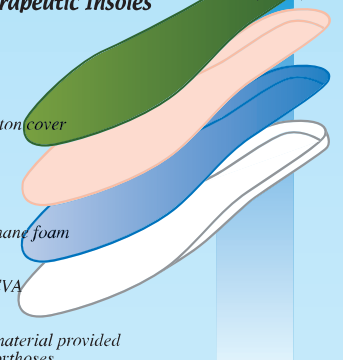

additional EVA material provided for customizing orthoses

Designed by a leading American podiatrist, the GentleStep™ shoe provides the ultimate in comfort and protection. Constructed with the latest in bio-compatible materials, it is light weight, machine-washable, and vented for breathability. For maximum shoe comfort and functionality, a pair of GentleStep Orthoses™ insoles is included with each pair of shoes. Also sold separately, these insoles offer state-of-the-art, multi-density construction.

INDICATIONS: diabetic foot lesions, arthritis, corns, bunions, hammer toes, poor circulation, etc.

The Wound Care Shoe System™ by Darco.

Now the incidence of amputations can be reduced in at-risk patients with the new custom off-loading *Wound Care Shoe System™* by Darco.

Full Pairs Only

The Darco Wound Care Shoe System provides another tool for you to use in the battle to further reduce the amputation rate in patients with ulcers or infections of the feet. While appropriate antibiotics and surgical intervention are important in treatment, they are ineffective unless weight is off-loaded from the area of the foot being treated. The shoe incorporates a system of multi-density insoles that may be cut or otherwise altered to off-load weight and pressure away from the ulcer. The insoles are contained within the semi-rigid rocker sole surrounded by a circumferential counter to prevent slipping of the insoles. The rocker sole assists in ambulation while reducing friction and pressure from vulnerable areas of the foot. The soft upper of the shoe is constructed of top quality EVA lined leather that can be modified to protect the lesion being treated and reduce the occurrence of window edema.

- For open wounds, low density EVA relieves pressure from ulcer by forming a concave shape over holes cut in medium and high density EVA layers. The bottom layer of high density foam absorbs the shock.
- For closed wounds, the bottom layer of high density foam is moved up to the second layer to provide more support for healing. This system allows for effective treatment of varying types of ulcers

Wound Care Shoes
50DRWC in Black
Sizes: Small, Sm/Med, Medium, Large, X-Large, 2x-Large

Rocker sole aids in ambulation and the depth sole accommodates layers of multi-density insoles to prevent slippage.

Long adjustable straps accommodate a wide range of bandages used and may be shortened as bandage bulk decreases.

The soft EVA liner covers and protects lesions.

Sections of the outer leather upper may be removed to relieve pressure over bony prominences or ulcers.

Altered insoles effectively redistribute weight away from foot lesions



TERMS:

FOB Yonkers, New York

We Accept Visa, Mastercard, American Express, and Discover

PACKING CHARGE:

Packing charge on orders less than \$125 to one address.

RETURNS:

Stock shoes in new condition are returnable in 30 days at customer's expense, less a per pair restocking charge. Original transportation and packing charges are not reimbursed except in cases of documented shipping errors. No shoes or merchandise are returnable after 30 days except for shoes with defects in materials or workmanship. However, if shoes have been marked, soiled or altered, we reserve the right to refuse credit entirely, or to allow only partial credit based on wear received. All returns should be neatly boxed and include copies of invoices or a return memo indicating date of purchase, customer account number, and reason for return.

SINGLES AND MISMATES:

Available only as indicated. No half pairs on Tarso Supinator®, TM2000®, Tarso Medius with Thomas Heel, Mobility, or Pulman. Half pairs billed at one half list price plus a per shoe, single shoe charge.

BACKORDERS:

We do not backorder unless you tell us to do so. If we are short of sizes, we cancel, unless told to keep these sizes on our backorder list until available.



All prices and specifications subject to change without notice.
No claims for shortages or non-delivery after 15 days.

To Assist In Payment We Accept



MARKELL

504 Saw Mill River Road
Yonkers, New York 10701
914-963-2258, FAX: 914-963-9293
e-mail: info@markellshoe.com

VISIT OUR WEB SITE: WWW.MARKELLSHOE.COM





M.J. MARKELL SHOE CO., INC.

504 Saw Mill River Road • Yonkers, NY 10701

914-963-2258 • FAX: 914-963-9293

e-mail: info@markellshoe.com

VISIT OUR WEB SITE: WWW.MARKELLSHOE.COM